

A fluidized bed for the combustion of coal, with limestone, is replenished with crushed coal from a system discharging the coal laterally from a station below the surface level of the bed. A compartment, or feed box, is mounted at one side of the bed and its interior separated from the bed by a weir plate beneath which the coal flows laterally into the bed while bed material is received into the compartment above the plate to maintain a predetermined minimum level of material in the compartment.

4335661

### FLUIDIZED BED HEAT EXCHANGER HAVING AN AIR ASSISTED BED DRAIN

Robert D. Stewart; Thomas E. Taylor; assigned to Foster Wheeler Energy Corporation

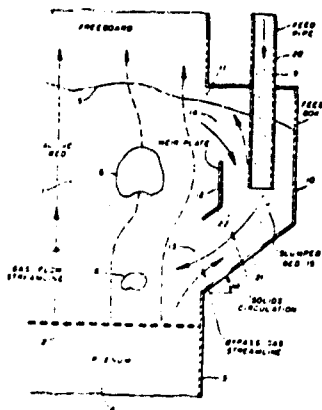

A fluidized bed heat exchanger in which a perforated plate is disposed within a housing for supporting a bed of particulate material. Air is passed through the plate to fluidize the particulate material and nozzles are provided for distributing air across the inlet end of a drain pipe for the spent particulate material to insure a continuous draining of the material.

4334898

### DEVICE FOR THE PRODUCTION OF SOLID ALUMINUM CHLORIDE

Gerhard Zhuber-Okrog; Ernst Kowolik; Haspeter Alder; Hans P. Mueller; assigned to Swiss Aluminium Ltd

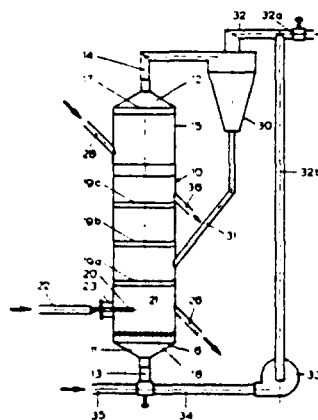

A device for producing solid aluminum chloride from gas containing gaseous aluminum chloride by means of a fluidized bed condenser. Between the inlet pipe for carrier gas and an outlet pipe for residual or waste gas there is a distributor plate with openings in the form of nozzles, at least one cooling facility, a feeding facility for the supply of gas containing gaseous aluminum chloride and a facility for drawing off the solid aluminum chloride. The outlet pipe for waste or residual gas is connected to the inlet pipe for carrier gas via a separator which separates out fine particulate aluminum chloride, which is then fed back to the bed to act as nuclei.

4334056

### METHOD FOR POLYTROPICALLY PRECIPITATING POLYAMIDE POWDER COATING COMPOSITIONS WHERE THE POLYAMIDES HAVE AT LEAST 10 ALIPHATICALLY BOUND CARBON ATOMS PER CARBONAMIDE GROUP

Klaus-Rudol Meyer; Karl-Hein Hornung; Rainer Feldmann; Hans-Jurje Smigerski; assigned to Chemische Werke Huls AG

Polyamide powder coating compositions for the coating of metals at high temperatures are obtained by the precipitation method from polyamides having at least 10 aliphatically bound carbon atoms per carbonamide group, copolyamides having at least 70% of these polyamides and mixtures of homopolyamides and copolyamides having at least 70% of these polyamides. A. For the preparation of powder coating compositions useful in the fluidized bed coating method the polyamides with 10 or more carbon atoms and having a relative viscosity between 1.4 and 1.8 are added to at least twice the amount by weight of ethanol and while the mixture is being mechanically mixed in a closed vessel is converted into a solution at temperatures between 130 degrees and 150 degrees C. This solution is adjusted to a precipitation temperature of between 100 degrees and 125 degrees C. while avoiding the formation of local sub-cooling and is agitated under an inert gas atmosphere to suppress boiling. Without further heat supply, powders with a grain size distribution of at least 99.5% by eight between 40 and 250 microns are precipitated at a low angular speed of agitation. When the particle formation is terminated, the suspension formed is cooled to at least 70 degrees C. and following partial mechanical separation of the ethanol, first drying takes place at reduce pressure with wall temperatures at not more than 100 degrees C. with mild mechanical agitation and after the onset of friability the wall temperatures can be increased up to 150 degrees C. with stronger mechanical agitation. B. For the preparation of powder coating compositions useful in the electrostatic coating method the method of A is modified in the precipitation step by using a higher angular speed of agitation for the purpose of preparing a grain size distribution of 100% by weight smaller than 100 microns.

4333909

**FLUIDIZED BED BOILER UTILIZING PRECALCINATION OF ACCEPTORS**

Robert D. Stewart; Robert L. Gamble; assigned to Foster Wheeler Energy Corporation

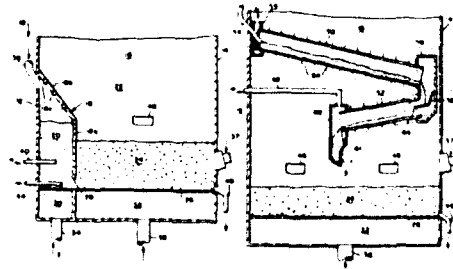

A fluidized bed boiler, and a method of operating same in which air is passed through a grate to fluidize a bed of particulate material containing fossil fuel disposed on the grate. A raw acceptor for the sulfur produced as a result of the combustion of the fuel is introduced into the housing and confined within an area of the housing isolated from the bed of particulate material. The area containing the acceptor is maintained at conditions optimal for calcining the acceptor, after which the latter is introduced into the fluidized bed.

4333445

**FLUIDIZED BED SOLAR ENERGY HEATER**

Donald M. Lee

